



**Advanced Card Systems Ltd.**  
Card & Reader Technologies

# **ACR39U-NF PocketMate II** **( USB Type C )** **Smart Card Reader**



Technical Specifications V1.03



## Table of Contents

<b>1.0.</b>	<b>Introduction .....</b>	<b>3</b>
1.1.	Smart Card Reader.....	3
1.2.	Ingenious Design .....	3
1.3.	Ease of Integration.....	3
<b>2.0.</b>	<b>Features .....</b>	<b>4</b>
<b>3.0.</b>	<b>Supported Card Types.....</b>	<b>4</b>
3.1.	MCU Cards .....	5
3.2.	Memory-based Smart Cards.....	5
<b>4.0.</b>	<b>Typical Applications .....</b>	<b>6</b>
<b>5.0.</b>	<b>Technical Specifications .....</b>	<b>7</b>



## 1.0. Introduction

ACR39U-NF PocketMate II (USB Type C) is a portable smart card reader that has more to it than meets the eye. As small and elegant looking as it is, this smart card reader is capable of supporting demanding smart card applications using full-sized contact smart cards. It provides the perfect balance between reliable functionality and design aesthetics to meet your security needs in many fields, including e-Banking, e-Payment, and e-Government.

### 1.1. Smart Card Reader

ACR39U-NF PocketMate II (USB Type C) supports ISO 7816 Class A, B, and C smart cards (5 V, 3 V, and 1.8 V) and microprocessor cards with T=0 and T=1 protocol. In addition, it supports a wide variety of memory cards in the market including the Department of Defense Common Access Card (CAC), and SIPRNET Card. This makes it ideal for a broad range of solutions such as PIV Application, Physical and Logical Access Control, Digital Signature, and Online Banking.

It connects with computers through its USB Full Speed interface and has a smart card read/write speed of 600 Kbps. This small device proves to be a powerful smart card reader as it houses the ACR39 core, which has been proven to support highly demanding smart card applications.



### 1.2. Ingenious Design

The highly compact ACR39U-NF PocketMate II (USB Type C) is specifically designed to be brought and used anytime, anywhere. No larger than a standard USB token, it transforms into a smart card reader for full-sized contact smart cards with just a single swivel motion.

### 1.3. Ease of Integration

Being a PC/SC and CCID-compliant device, ACR39U-NF PocketMate II (USB Type C) can easily be integrated in a computer-based environment. Its drivers are compatible with operating systems such as Windows®, Linux®, Mac OS®, and Solaris. In addition, ACR39U PocketMate II may now be used on mobile devices running the Android™ platform with versions 3.1 and later.

With its various features, ACR39U PocketMate II series is the perfect smart card reader for your smart card solution.



## 2.0. Features

- USB 2.0 Full Speed Interface
- USB Type C Connector
- Plug and Play – CCID support brings utmost mobility
- Swivel Motion Design
- Smart Card Reader:
  - Contact Interface:
    - Supports ISO 7816 Class A, B, and C (5 V, 3 V, 1.8 V) cards
    - Supports CAC (Common Access Card)
    - Supports SIPRNET Card
    - Supports J-LIS Card
    - Supports microprocessor cards with T=0 and T=1 protocol
    - Supports memory cards
    - Supports PPS (Protocol and Parameters Selection)
- Features Short Circuit ProtectionApplication Programming Interface:
  - Supports PC/SC
  - Supports CT-API (through wrapper on top of PC/SC)
- Supports Android™ 3.1 and later<sup>1</sup>
- Compliant with the following standards:
  - EN 62368/IEC 62368
  - CE
  - FCC
  - RoHS
  - REACH
  - EMV™ Level 1 (Contact)
  - J-LIS
  - KCC
  - PBOC
  - TAA (USA)
  - UKCA
  - VCCI
  - WEEE
  - ISO 7816
  - PC/SC
  - CCID
  - Microsoft® WHQL

---

<sup>1</sup> Uses an ACS-defined Android Library



## 3.0. Supported Card Types

### 3.1. MCU Cards

ACR39U PocketMate II operates with MCU cards following either the T=0 or T=1 protocol. It also works with SIPRNET, and CAC cards, ideal for US PIV and PKI applications.

### 3.2. Memory-based Smart Cards

ACR39U PocketMate II works with several memory-based smart cards such as:

- Cards with intelligent 1 KB EEPROM with write-protect function, including:
  - Infineon®: SLE4418, SLE4428, SLE5518 and SLE5528
- Cards with intelligent 256-byte EEPROM with write-protect function, including:
  - Infineon®: SLE4432, SLE4442, SLE5532 and SLE5542



## 4.0. Typical Applications

- e-Government
- e-Banking and e-Payment
- e-Healthcare
- Public Key Infrastructure
- Network Security
- Access Control
- Loyalty Program



## 5.0. Technical Specifications

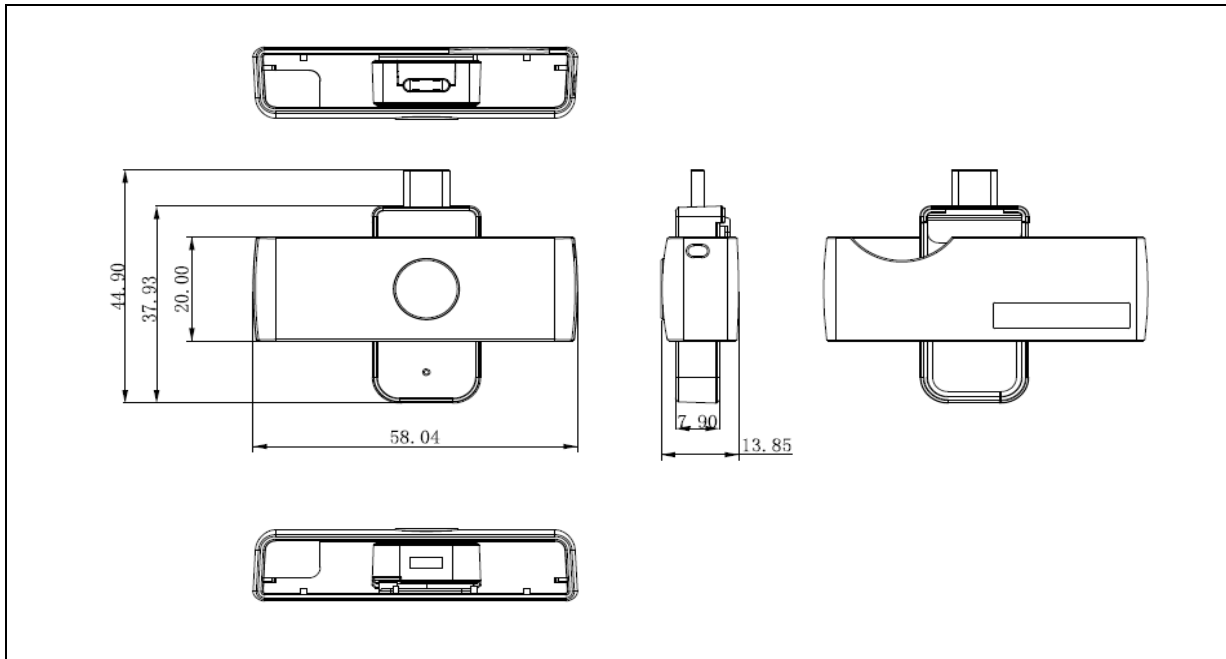

### Physical Characteristics

Dimensions ..... 58.0 mm (L) x 20.0 mm (W) x 13.9 mm (H)  
Weight..... 10 g  
Color ..... White

### USB Host Interface

Protocol..... USB CCID  
Connector Type..... Standard Type C  
Power Source..... From USB port  
Speed..... USB 2.0 Full Speed (12 Mbps)  
Supply Voltage..... 5 V

### Contact Smart Card Interface

Number of Slot ..... 1 Full-sized Card Slot  
Standard ..... ISO 7816 Parts 1-4, Class A, B, C (5 V, 3 V, 1.8 V)  
Protocol..... T=0; T=1; Memory Card Support  
Supply Current ..... Max. 50 mA  
Smart Card Read/Write Speed..... 9.6 Kbps – 600 Kbps  
Short Circuit Protection ..... (+5) V/GND on all pins  
Clock Frequency ..... 4.8 MHz  
Card Connector Type..... Contact  
Card Insertion Cycles..... Min. 100,000

### Built-in Peripheral

LED ..... Green

### Application Programming Interface

PC-linked Mode..... PC/SC  
..... CT-API (through wrapper on top of PC/SC)

### Operating Conditions

Temperature ..... 0 °C – 60 °C  
Humidity ..... Max. 90% (non-condensing)  
MTBF ..... 500,000 hrs

### Certifications/Compliance

EN 62368/IEC 62368, CE, FCC, RoHS, REACH, EMV™ Level 1 (Contact), J-LIS, KCC, PBOC, TAA(USA), UKCA, VCCI, WEEE, ISO 7816, USB 2.0 Full Speed, PC/SC, CCID, Microsoft® WHQL



**Device Driver Operating System Support**

Windows® 7, Windows® 8, Windows® 8.1, Windows® 10  
 Windows® Server 2003, Windows® Server 2008, Windows® Server 2008 R2, Windows® Server 2012, Windows® Server 2012 R2, Windows® Server 2016  
 Linux®, Mac OS®, Solaris, Android™ 3.1 and later



Android is a trademark of Google Inc.  
 EMV is a registered trademark or trademark of EMVCo LLC in the United States and other countries.  
 Infineon is a registered trademark of Infineon Technologies AG.  
 Linux® is the registered trademark of Linus Torvalds in the U.S. and other countries.  
 Mac OS is a trademark of Apple Inc., registered in the U.S. and other countries.  
 Microsoft, Windows, and Windows Vista are registered trademarks of Microsoft Corporation in the United States and/or other countries.